

THE 2-33 SAILPLANE
FLIGHT - ERECTION - MAINTENANCE
MANUAL



AIRCRAFT CORP.

ELMIRA, N. Y.

SCHWEIZER SGS 2-33 and 2-33A
FLIGHT - ERECTION - MAINTENANCE
MANUAL

The Model SGS 2-33A Sailplane is the same as Model SGS 2-33 except for the rudder used. SGS 2-33 uses rudder, P/N 26K714 -3, whereas Model SGS 2-33A uses rudder, P/N 33700K-1. The 33700K-1 rudder is taller and incorporates a balance weight in the upper forward end which overhangs the top of the fin. The static-unbalance limits of the 33700K 1 rudder, after covering and finishing is complete, is 10 to 13 in./lbs. tail-heavy, measured from the hinge center line.

Serial Numbers 86 and up incorporate the balanced rudder in factory production. Serial numbers prior to No. 86 may be converted to Model SGS 2-33A by changing the rudder and accomplishing the documentation of same in accordance with manufacturer's Service Letter No. SL-102-4.

Flight, Erection and Maintenance instructions contained in this Manual are identical for both Models, SGS 2-33 and SGS 2-33A.

SCHWEIZER AIRCRAFT CORP.

BOX 147

ELMIRA, N. Y. 14902

G2EA

2

Production basis Production Certificate No. 101

Equipment: The basic equipment as prescribed in the applic
certification basis) must be installed in the aircr

Form F-114

3-78

TABLE OF CONTENTS

1-i

SECTION ONE - FLIGHT PROCEDURES

General Description	1-2
Supplement No. 1 to SGS 2-33A F-E-M Manual	1-2a
Cockpit (Illustration)	1-3
Preflight	1-4
Winch or Auto Tow	1-5
Free Flight	1-5
Landing	1-7
Flight Procedures - Strong Winds	1-8
Flight Envelope Information	1-9
Flight Envelope Graph	1-10
Weight and Balance Calculations	1-11
Calculated Performance Curves	1-15

SECTION TWO - ERECTION & MAINTENANCE

2-i

Erection Procedure	2-1
Installation of Stabilizer and Elevator	2-2
Installation & Removal of Fin and Rudder	2-3
General Maintenance	2-4
Lubrication - Figure 1	2-5
Leveling - Figure 3	2-6
Preflight Inspection	2-7
Annual and/or 100 Hour Inspection	2-8

- NOTE 1. Suitable placards to cover the various pilot and passenger weights r
as determined from the manufacturer's weight and balance report.
- NOTE 2. The following placards must be installed in full view of the pilot:
- (a) "Solo front seat only."
- (b) "Max. glide or dive 98 m.p.h.
Max. aero tow 98 m.p.h.
Max. auto-winch tow 69 m.p.h.
- NOTE 3. Approved safety belt and shoulder harness required for each occup
- NOTE 4. Each Model SGS 2-33A glider assembled from a kit is designated M
will be eligible for an airworthiness certificate when accompanied b
constructed in exact accordance with the approved drawings and m
furnished by the manufacturer in the kit have been used; and furthe
been satisfactorily passed:
- (a) An inspection for workmanship, materials, and conformity bef
woodwork may be sealed.)
- (b) A final inspection of the completed glider.
- (c) Check of flight characteristics.

...END...

GENERAL DESCRIPTION

The SGS 2-33 is a conventional two-place tandem, intermediate-training sailplane, manufactured by Schweizer Aircraft Corp., Elmira, New York. Its construction is all metal with fabric cover on the fuselage and tail surfaces. It has a one piece canopy for increased visibility. The wings are tapered in the outboard section, and have dive-brakes incorporated.

Overall dimensions are: Length - 25' 9"
 Span - 51' 0"
 Height - 9' 3-1/2"
 Wing View - 219.48 sq. ft.
 Aspect Ratio - 11.85-1

Flight Controls -

1. Tow release knob:
 Front - located at center bottom of instrument panel.
 Rear - located at tope left of front seat back.

 To release - pull red knob full out.
2. Dive Brake and Brake Lever:
 Front - located at left side of cockpit under instrument panel.
 Rear - located at center of left side of cockpit.

 To use dive brake, push forward and down and then straight back. The wheel brake is actuated only at the extreme aft position of the dive-brake/wheel brake control handle.
3. Control sticks:
 Front and Rear - are conventional and both are mounted on a single torque tube.
4. Rudder Pedals:
 Front - located on left and right forward of floor board and are conventional. They are toe type pedals and are adjustable.
 Rear - located to left and right of front seat and are not adjustable.
5. Trim Lever:
 Front only - located on left side below dive brake lever.
 Four positions from full forward to full rearward.
 Use as needed.
6. Instruments:
 Front only - ASI is required. Additional instruments may be added, up to full panel, as desired.
NOTE: Instrument flight is prohibited, regardless of instrumentation.

**DEPARTMENT OF TRANSPORTATION
 FEDERAL AVIATION ADMINISTRATION**

GLIDER DATA SHEET NO. G2EA

This data sheet which is a part of type certificate No. G2EA prescribes conditions and lii which the type certificate was issued meets the airworthiness requirements of the Federal

Type Certificate Holder	Schweizer Aircraft Corporation
	County Airport
	Elmira, New York 14902

I - Model SGS 2-33, 2 PCLM, Approved February 10, 1967; Model SGS 2-33A, 2 PCLM, Approved April 19, 1973. Model SGS 2-33A same as aerodynamic balance; Model SGS 2-33AK is same as Model SGS 2-33A constructed from requirements)

Type	Class II, Utility	
Airspeed limits (CAS)	Vne-Glide or dive	98 m.p.h
	Vta-Airplane tow	98 m.p.h
	Vtaw-Auto-winch tow	69 m.p.h
C.G. range	(+11.9) to (+19.8) (Fuselage Sta. 78.2 to 86.1)	
Maximum weight	1040 lb.	
No. seats	2 (1 at -23) (1 at +8)	
Baggage	None	
Control surface movements	Elevator	Up 23°
	Rudder	Left 30°
	Aileron	Up 38°
	Dive Brakes	Top Up 85°
Serial nos. eligible	1 and up	

Specifications Pertinent to All Models

Datum	Wing leading edge at root (Fuselage Sta. 66.3)
-------	--

SAILPLANE TIE DOWNS

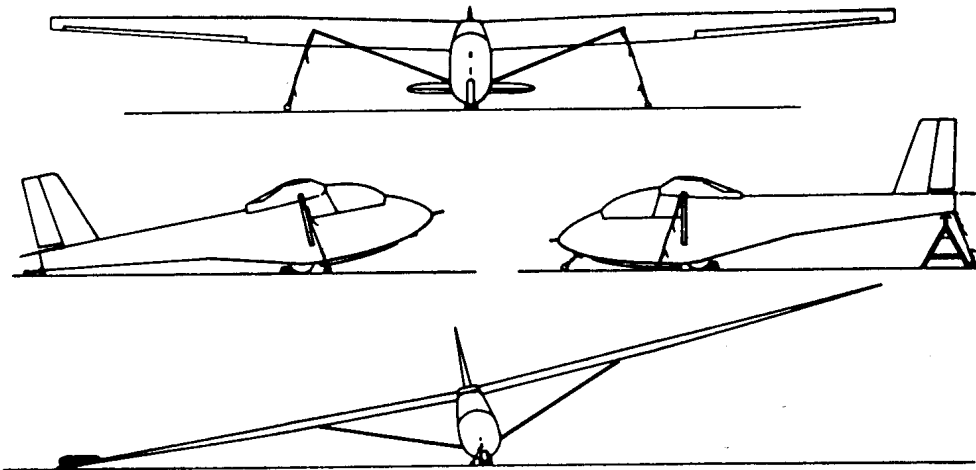

Many more sailplanes are damaged on the ground by the wind than in flying accidents. It is usually due to leaving the ship unsecured or using inadequate tie downs.

In the normal, tail down, ground position, the wing has a high angle of attack. A 2-22 or 2-33 (empty wgt. 500#), facing into the wind will be subjected to lift forces as shown:

<u>WIND</u>	<u>LIFT</u>	<u>NET LIFT</u>	<u>WIND</u>	<u>LIFT</u>	<u>NET LIFT</u>
30 mph	750	250#	60 mph	2,900	2,400#
40 mph	1,300	800#	70 mph	3,950	3,450#
50 mph	2,000	1,500#	80 mph	5,200	4,700#

Therefore, it is very important that adequate tie downs are provided. The following procedures are recommended:

1. Sheltered Area: Tail down, ropes (*), at wings and tail (**).
2. Unsheltered Area: Facing into prevailing wind. Rope at wings and tail, and chain tie down to release hook.
3. Unsheltered - High Wind Hazard: Tail supported on padded stand. Rope to wings and two ropes to tail. Short chain (5/16" welded link), tie down to tow hook.
4. Flightline Tie Down: Short chain tie down to tow hook (tail in air). Water filled tire tube on end of one wing.

NOTE: *Minimum size of recommended ropes - 5/16" nylon, or 1/2" manila - renewed each season. (Knots can reduce rope strength by 50%.)

- ** Size and style of ground anchor will depend on soil composition and type of sailplane. In light sandy soils, anchor arm or chain longer and set deeper. A ground anchor should be able to withstand a vertical pull of at least 2,000#. Should not be located directly under tie downs.
- *** Rudderlock - recommended if control locks are not used. Ailerons and elevator can be secured with seat belt around control stick.
- **** Securing the spoilers or dive brakes open will decrease lifting forces.

Flight-Erection-Maintenance Manual

FLIGHT CONTROLS-

2. Dive Brake & Wheel Brake (Ref. Item 2 on Page 1-2)

Beginning with SGS 2-33A, Serial No. 500, a new main landing wheel, including a hydraulic brake installation (P/N 332162) is provided, superseding the mechanical brake.

The hydraulic brake is rigged so that it is actuated only at the extreme aft position of the divebrake/wheelbrake control handle.

The main wheel is a split-rim type (Cleveland Model 40-97D) incorporating a Cleveland Model 30-63D hydraulic brake. This is a disc type brake, actuated by a Gerdes Products A049-3P master cylinder located adjacent to the control bellcrank on the left hand side, aft of the rear seat.

The brake system is serviced with hydraulic fluid (specification MIL-H-5606, or equivalent) by removing the plastic plug from the top plate on the master cylinder and filling through this hole.

To bleed the brake system, remove the bleeder-valve cap on the wheel brake assembly opposite the line-attach point. Actuate the brake master cylinder and while maintaining pressure crack the bleeder-valve screw at the wheel brake to allow air to escape. Repeat this cycle, adding hydraulic fluid as necessary, until the air is exhausted. Check brakes for normal operation; then tighten the bleeder valve screw and replace the bleeder-valve cap. Also replace the plug in the brake master cylinder filler hole

Supplement No. 1 (Cont'd)

FLIGHT CONTROLS CONT'D:

5. Trim Lever (Reference Item 5 on Page 1-2)

On sailplane serial no. 500 and up, a ratchet-lock trim installation (P/N 33140G) is provided, superseding the bungee-type trim found on lower serial-number ships.

The trim control lever for the ratchet-lock trim system is located just forward and to the left of the front cockpit control stick. The system is integral with the forward control stick and torque tube assemblies.

The trim is operated with the fingers of control stick hand by aft pressure on the locking lever. The control stick is then moved to the position which gives the desired airspeed, at which point the locking lever is released to engage the trim lock.

Prior to take-off, the trim should be set (locked) at the elevator-neutral position which is checked by stick line-up with the trim placard neutral-arrow, located on the floorboard to the left of the control stick.

After take-off, the desired trim settings may then be obtained as noted above.

Maintenance of the ratchet lock trim system is limited to maintaining security of attachments and periodic lubrication, with special attention to the spring-cartridge, per codes "A" and "B", Page 2-5 of the Erection and Maintenance Instructions section of this manual. There are no field adjustments to be made to the trim system or the spring cartridge.

ANNUAL/100 HOUR INSPECTION cont'd.6. Cabin Group:

- a. Inspect instruments for range markings, zero reading and security of attachment.
- b. Inspect instrument panel for security of attachment.
- c. Inspect nameplate, decals for legibility and security of attachment. Check "Flight Limits" placard for correct Min./Max. Pilot weights per current weight and balance statement.
- d. Inspect air-vent for operation and security of attachment.
- e. Inspect seats for damage and security of attachment.

REMOVABLE BALLAST FOR SGS 2-33 and 2-33A

A removable ballast installation part number 33011D has been developed for the SGS 2-33 and 2-33A models to simplify the balance requirements necessary for a relatively light weight pilot flying solo.

The installation consists of a cannister assembly which is securely attached to the sailplane structure in a well forward location for maximum effectiveness. The ballast proper, is a cast lead bar with a handle for convenience in inserting or removing from the cannister. A snap-in pin retains the ballast in place. For each ballast installation, a special "Flight Limits" placard is installed and is stamped to show the resultant actual minimum and maximum pilot weights when the removable ballast is in place. These figures are calculated for each sailplane based on the current weight and balance at the time the ballast is installed.

This installation provides a safe and convenient means of ballasting for flight for the light-weight pilot without the penalty of reduction of useful load, as would be incurred by a like amount of permanent ballast.

3. Empennage Group cont'd.

- h. Check fabric and finish on stabilizer, elevator and rudder for cracks and deterioration. (Check tensile strength, if below 35 pounds per inch fabric must be replaced.)

See Note under D. 1. i., above

4. Wing Group:

- a. Remove wing gap cover, inspect wing attachment fittings and bolts for condition and security of attachment.
- b. Inspect aileron push rods for condition and security of attachment.
- c. Inspect dive brake linkage for corrosion, wear and security of attachment.
- d. Inspect wing struts, strut fittings and attachment bolts for condition and attachment.
- e. Inspect fixed surfaces for dents, corrosion, loose rivets and other signs of structural failure or damage.
- f. Inspect ailerons and hinges for condition, operation and attachment.
- g. Inspect aileron belleranks for condition, evidence of damage and attachment.
- h. Inspect dive brake mechanism and hinges for condition, operation and attachment.
- i. Inspect wing tip wheels for damage and attachment.
- j. Inspect push rod fairleads for wear or breakage and attachment.

5. Tow Hook:

- a. Inspect hook for wear, cracks, roughness and attachment.
- b. Check mechanism for freedom of operation. Lubricate guide-tubes with a dry stick-type lubricant.
- c. Check release mechanism by applying a force of 6-12 lbs. Ref. paragraph B. 3. d. and Figure 2.
- d. Check ring clearance between hook and fuselage when hook is closed, using a 2-1/4" O.D. ring made from 5/16" dia. stock.

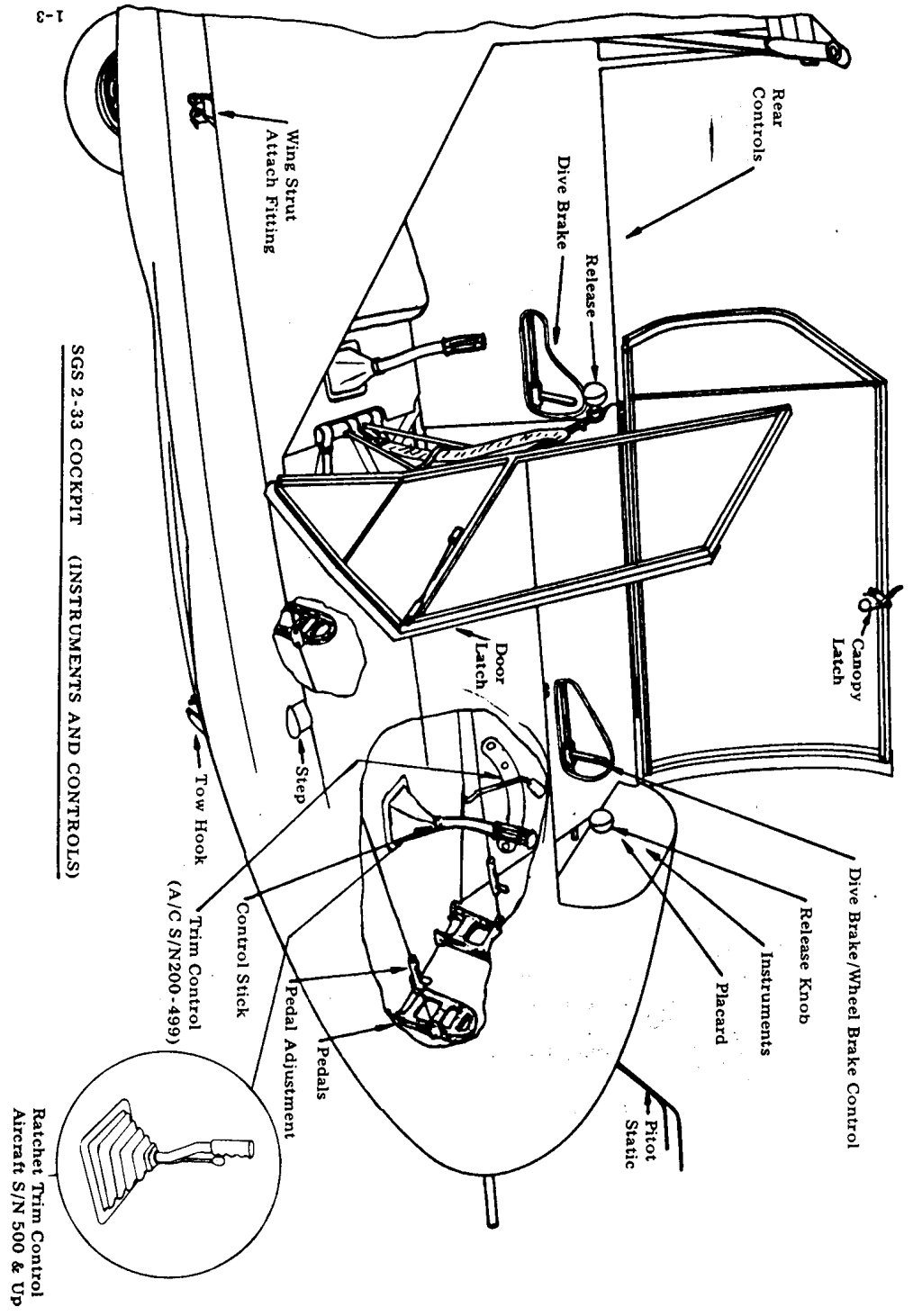

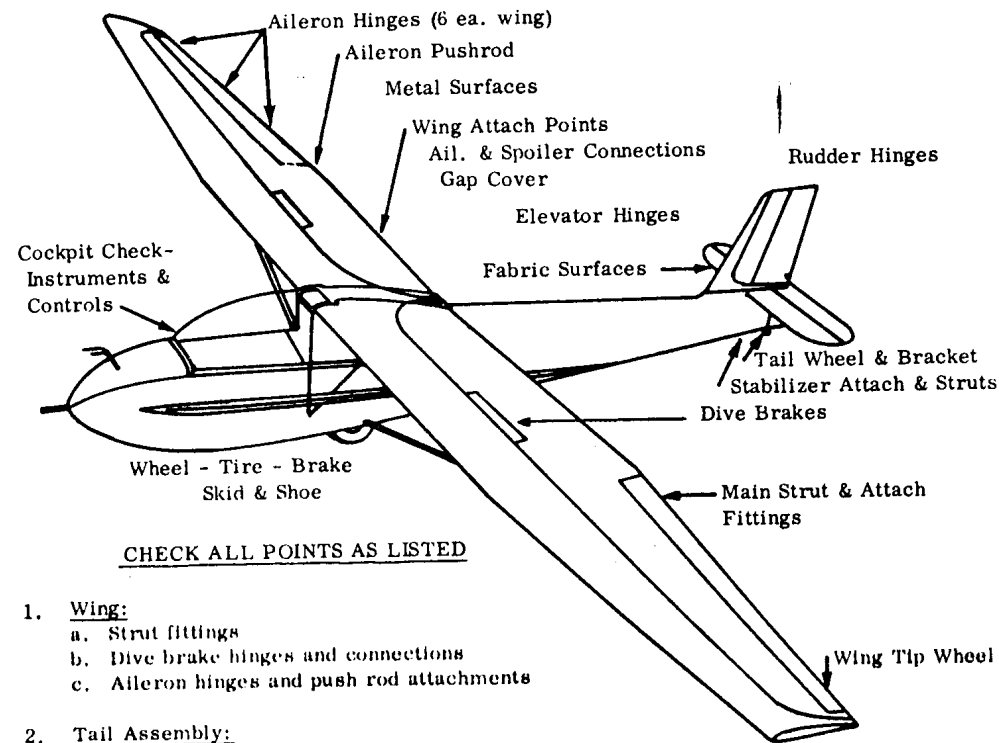
PREFLIGHT INSPECTIONCHECK ALL POINTS AS LISTED

1. Wing:
 - a. Strut fittings
 - b. Dive brake hinges and connections
 - c. Aileron hinges and push rod attachments
2. Tail Assembly:
 - a. Hinge points, rudder and elevator
 - b. Pushrod attachment to elevator horn
 - c. Stabilizer struts and stabilizer attachment to fuselage.
 - d. Rudder cable connection to rudder horn
 - e. Tail wheel assembly
3. Fuselage:
 - a. Release control
 - b. Flight controls for free movement including release
 - c. Instruments
 - d. Canopy attach points and latch
 - e. Safety belts and shoulder harnesses
 - f. Rear door and window attach points and latches
 - g. Fabric for damage
 - h. Wheel, tire and brake
 - i. Static and pitot tubes for water or other foreign objects.
4. Tow Rope:
 - a. Condition and attachment of rings.

1. Fuselage Group (cont'd.)

- i. Check fuselage fabric and finish for cracks and deterioration (check tensile strength, if below 35 pounds per inch fabric must be replaced.)

NOTE: A synthetic fabric "Ceconite 103" manufactured by Cooper Engineering Co., Box 3428, Van Nuys, California 91405, is used on the aircraft. The "Ceconite Process" * procedure Manual No. 101" should be procured from them for guidance in repair and maintenance of this fabric. FAA Manual No. AC43.13-1 (Superseding CAM 18) is also used as a guide for testing and repairs - See Chapter 3. *Trade Mark R Registered in U. S. Patent Office and Canada.

- j. Check canopy and rear door for condition latches and attachment.
- k. Check plexiglas for cracks or excessive crazing.
- l. Check safety belts, shoulder harness, brackets and bolts.
- m. Check springs for corrosion, cracks and wear at ends.
- n. Check bungee control latch plate, if badly worn, replace.
- o. Dive-brake/wheel-brake mechanism for wear, alignment and linkage attachment. Lubricate control rod at forward guide with a dry stick-type lubricant.

2. Landing Gear Group:

- a. Remove wheel, inspect for brakes.
- b. Inspect wheel bearings for condition, repack.
- c. Check tire pressure (15 lbs. sq. in.)
- d. Inspect tire for wear and cuts.
- e. Inspect tail wheel and bracket for cracks and wear.
- f. Inspect skid and shoe for cracks, wear and attachment.
- g. Inspect brake for wear and operation.

3. Empennage Group:

- a. Inspect stabilizer for condition and attachment.
- b. Inspect stabilizer fittings and bolts for wear and signs of failure.
- c. Inspect stabilizer struts for damage and security of attachment.
- d. Inspect elevator and hinges for condition and security of attachment.
- e. Inspect elevator horn for condition and pushrod for security of attachment.
- f. Inspect fin for dents, general condition and attachment.
- g. Inspect rudder and hinges for condition and security of attachment.

Preflight Inspection (cont'd.):

- o. Tail wheel and bracket.
- p. Skid and skid shoe (Skid should be replaced if cracks or splits are evident. Shoe need not be replaced except for wear-through or breakage.)
- q. Shoulder harness and safety belts.
- r. Canopy.
- s. Release hook and release system.
- t. Pitot system (After prolonged tie-down or exposure to rainy weather, remove lines from instruments and expel any water which may have collected in lines through them.)

CAUTION: DO NOT BLOW INTO PITOT TUBE WITH INSTRUMENTS CONNECTED.

ANNUAL, AND/OR 100 HOUR INSPECTION, SGS 2-33

- 1. Fuselage Group:
 - a. Check control stick and torque tube assembly, lubricate torque tube support bearings. Inspect internal surface of torque tube for corrosion, clean and apply Paralketone if necessary.
 - b. Check controls for ease of operation.
 - c. Check control cables for safety, corrosion, wear and security of attachment.
 - d. Check elevator push tube for condition, wear, especially at fairlead and security of cable attachments. Also check fairlead for slippage in clamp.
 - e. Check fuselage members for cracks, misalignment and any other damage. Weld clusters for rust particularly in "cupped" areas without adequate drainage.
 - f. Note if the primer has been scraped off any fuselage member leaving exposed metal, sandpaper lightly to remove rust or impurities and touch up with zinc chromate primer, Specification MIL-P-8585A.
 - g. Check cable pulleys for wear and attachment, replace if necessary.
 - h. Check fairleads for wear and attachment, replace if necessary.

WINCH OR AUTO TOWS

Precautions:

- 1. Be sure equipment is suitable for purpose
- 2. Person driving car or operating winch should be experienced with equipment and know towing characteristics of the SGS 2-33.
- 3. Never hook rope or wire to empty sailplane.

Winch or auto tows may be executed in the usual manner using either the forward, or the CG release, although the latter should result in a higher altitude. There is no tendency to oscillate with either release. Maximum speed for auto, or winch tow, is 69 MPH.

CAUTION:

- 1. Do not climb at full back stick position until a safe height for stall recovery is reached (75 - 100 ft.).
- 2. Level out before releasing.

Aero Towing:

- 1. Trim (bungee lever) forward position recommended for solo take-off.
- 2. You will notice that aileron control is somewhat heavy at fast towing speeds, but they reduce to a normal level at slower speeds.

FREE FLIGHT

Flying Speeds:

Best gliding speed (L/D) 23-1 at 50 mph... 2 place
" " " (L/D) 23-1 at 45 mph... 1 place
Min. sinking speed 42 mph 3.1 FPS..... 2 place
" " " 38 mph 2.6 FPS..... 1 place

Flight Limits-speeds:

Dive - 98 mph
Aero Tow - 98 mph
Dive brakes extended - 98 mph
Auto or winch tow - 69 mph

Aerobatics:

Mild aerobatics to 80 mph can be done. Inverted flight prohibited.

Stalls:

Are very gentle and always straight ahead with no tendency to go off to either direction. Buffeting occurs before the stall 31 mph solo, 34 mph dual.

Spins The 2-33 will spin, depending on the weight of pilots and equipment, etc., Care should be taken to avoid stalls and spins at low altitude by using adequate air-speed.

Useful Loads The placard weight/s on the instrument panel must be strictly adhered to. This will insure that center of gravity will be maintained in flight. The weights stamped are maximums and minimums which are easily compared with that of the pilot and passenger.

NOTE: Seat ballast must be added if minimum weight of pilot/s is less than placard minimum.

Spiralling in thermals

In order to remain aloft or gain altitude it is necessary to spiral. The diameter of a thermal is normally quite small, therefore, a fairly steep bank is required. Although this is general practice, it may not be necessary in areas where large diameter thermals are found. The best flying speed in any thermal, at any degree of bank, is a few miles per hour above the buffet-before-the-stall.

<u>Example:</u>	<u>SGS 2-33</u>	
	<u>Solo</u>	<u>Dual</u>
Stalling speed-level flight	31 mph	33 mph
" " -30° bank	33.5 mph	35.5 mph
Buffeting	34-37 mph	35-38 mph
Spiralling speed	38 mph	42 mph

Keep in mind that the steeper the spiral, the higher the minimum-sink and stalling speed will be. Sometimes it is necessary to spiral very steeply and sacrifice slow speed and low sink to remain within the limits of the thermal. This is especially true in strong, small-diameter thermals.

Slipping The SGS 2-33 can be slipped both forward, and while turning. The slipping-turn is done in a normal procedure, but due to limited rudder area, the forward slip must be done with very little low wing and full rudder. The airspeed should be kept between 45 - 50 mph for fastest rate of descent.

2. **Leveling:**

- To level fuselage laterally, prop up the wing tips and test for horizontal on fuselage members, see Figure 3.
- To level longitudinally, prop up the tail and test for horizontal on the top longeron of fuselage aft of wing, see Fig. 3.

3. **Rigging:**

- The proper dihedral angle and angle of incidence are built into the wing and fuselage at the factory.
- Elevator and rudder control system rigging is accomplished by turn-buckles on the cables. Elevator cables are rigged to 30 ± 5 pounds tension. Rudder control system-tension is maintained by springs on rudder pedals. Cables should be rigged with turnbuckle threads flush with the barrel. Double-wrap turn-buckles in accordance with FAA Manual No. AC43.13-1, Figure 4.5, or MS33591.
- The Dive-brake/wheel-brake control linkage should be rigged so that there is no slack or lost motion when control is started. The wheel-brake cable is rigged so that the brake arm is actuated at the last 1-1 1/2" of control rod travel (after the dive-brakes have been effectively opened.)
- Tow hook release spring tension is checked by applying a force of 6-12 lbs. at the end of the release arm. The hook should then release. If the tension is not within this tolerance, the spring should be replaced. See Figure 2.

PREFLIGHT INSPECTION:

- Inspect the following for condition, operation, security of attachment and/or other signs of failure.
 - Wing and attachment bolts.
 - Struts and strut attachment bolts.
 - Stabilizer struts and attachment bolts.
 - Stabilizer.
 - Elevator.
 - Fin.
 - Rudder.
 - Fuselage covering and structural tubing.
 - Control cables.
 - Controls and control system push rods.
 - Ailerons.
 - Dive-brakes and controls.
 - Main wheel and brake.
 - Tire (maintain tire pressure at 15 lbs.)

SCHWEIZER AIRCRAFT CORPORATION
ELMIRA, N.Y. 14902

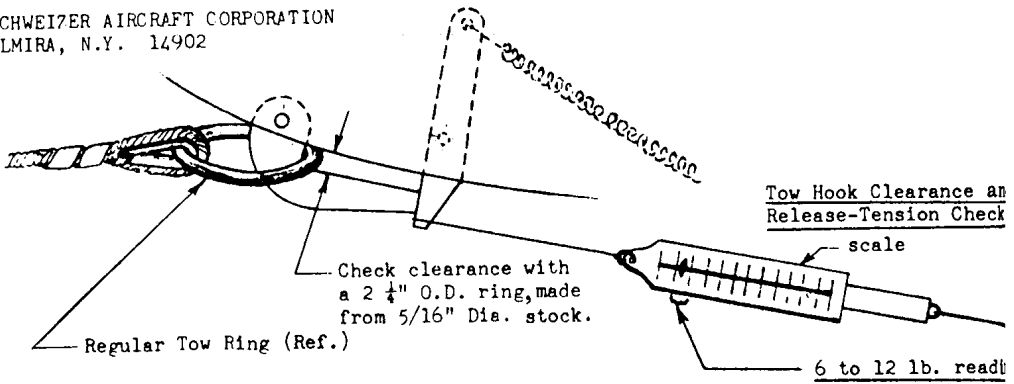

FIGURE 2.

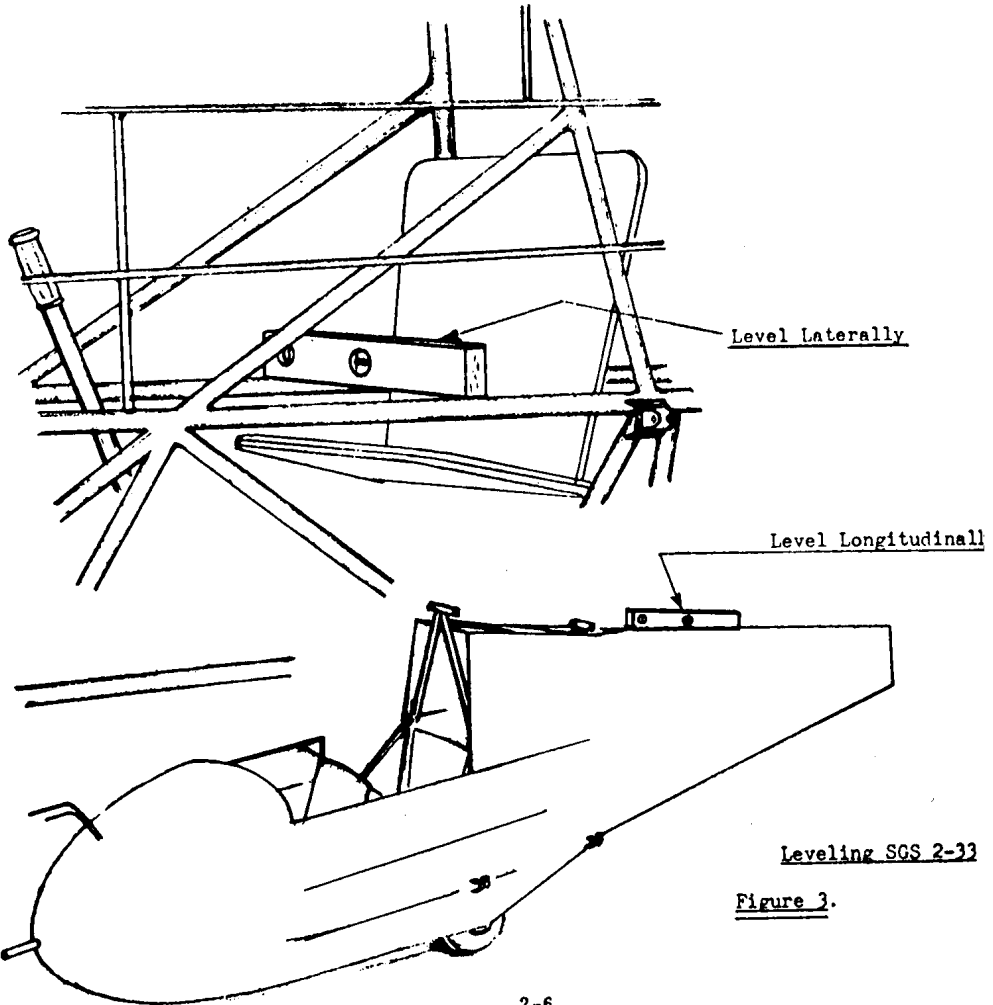

Figure 3.

LANDING

Pattern

It is general practice to fly a traffic pattern. Down-wind and base legs and final approach. Extra speed is also used depending on wind velocity and gust conditions. It is good practice to add 1 mph to airspeed for each mph of wind.

Spoilers

Approach should be made high, with use of dive brakes. Dive brakes increase sink, which in turn makes a steeper and more controllable glide path. They can also be used to lose altitude rapidly at any time during a flight, or during a tow to take up slack, or to lower sailplane from a too-high position. When flying solo, the stalling speed of the 2-33 is 31 mph with dive-brakes closed and 34 mph with dive-brakes open. For dual flight, the speeds are 33 mph and 35 mph, respectively.

It is unsafe, however, to make an approach with dive brakes open in the speed range of 36 to 43 mph as the rate of descent is so great that a proper flare-out for landing cannot be made.

Touch Down

Can be done with dive brakes either open or closed although it is preferable to land with them open. With dive brakes open, the glide path is quite steep, therefore, a flare-out must be executed 2 - 5 ft. above the ground at 43 - 46 mph. By holding a level attitude close to the ground, the sailplane will settle to a smooth, level touch-down. **DO NOT FLARE OUT TOO HIGH** - this will cause a very hard landing and may result in injury to occupants or sailplane.

Touch down with dive brakes closed

Is executed by letting the sailplane land itself at, or near, 40 mph. Be careful not to ease stick back after touch-down. This will cause a steeper angle of attack and the sailplane will lift off.

Taxiing after touch down

Even though sailplane is on the ground, it should literally be flown to a stop with use of all controls. Wheel brake may be used if a quick stop is desired or necessary.

Getting out of the 2-33

On the ground it is tail down when empty, and nose down with pilot in the seat. When pilot gets out he should keep his weight on the side of the cockpit until he is in a position to lower the tail gently to the ground.

GENERAL FLIGHT PROCEDURES IN STRONG WINDS

1. Be careful during ground handling operations.
Keep tail high going to and from tie down area.
2. Keep well up-wind of your landing area.
3. When going against wind, it is good practice to add wind velocity to air speed at best L/D.

EXAMPLE

Speed at best L/D (solo)	45 mph
Wind velocity	+ 15 mph
Desired speed	60 mph

This speed will give a better glide angle than a slower approach.

4. Land into the wind whenever possible. In crosswind landing, crab into the wind to maintain desired path over the ground and at the last moment, straighten ship to line of flight and touch down. Be careful while the ship is rolling.

Downwind landing in high winds - Land with brake full on and maintain control as long as possible.

TIE DOWNS

The 2-33 should never be left unattended in strong winds or gusty conditions. Tie down points are at each wing where main struts are attached and at tail wheel bracket. Be sure ropes and stakes used for tying down are adequate and in good condition.

SCHWEIZER AIRCRAFT CORPORATION
ELMIRA, NEW YORK 14902

SGS 2-33 LUBRICATION CHART

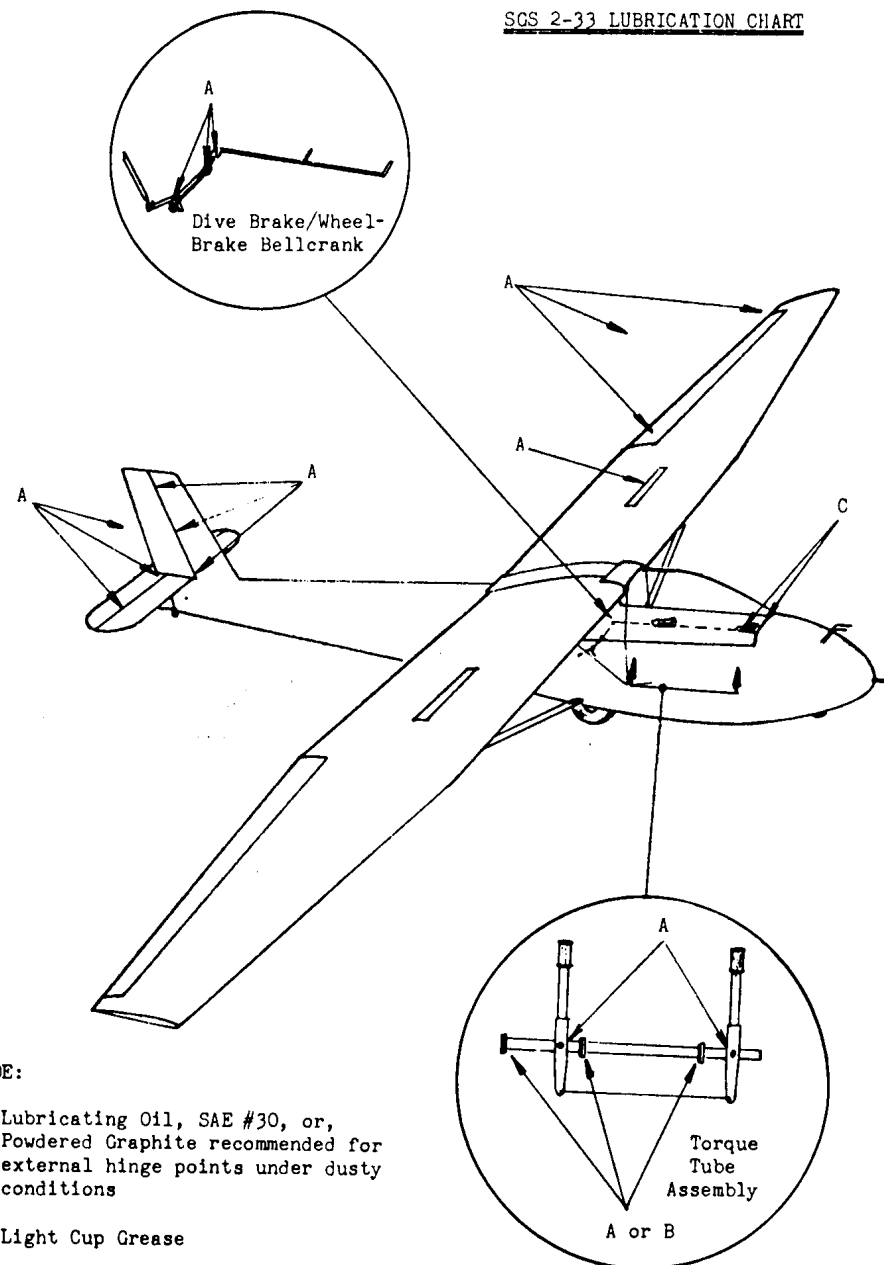

FIGURE 1.

E. PERFORM LINE INSPECTION TO DETERMINE THAT:

- a. All controls move freely in the correct direction with no binding or lost motion.
- b. All control components are properly safteed.
- c. Both dive brakes open equally and that wheel brake is actuated at the end of the control travel.
- d. That ailerons are in neutral, in conjunction with the stick position.

NOTES:

- 1. In view of the fact that the glider may have to be disassembled rather frequently in the field; the number of bolted attachments are kept to a minimum. However, should the owner or operator be so inclined, all of the attachment fittings may be made with appropriate AN bolts, nuts and cotter pins, replacing the clevis and safety pins specified. LSP-1 safety pin is an acceptable alternate for #1 and #2 commercial safety pin.
- 2. For trailering, the L. H. rear window should be removed and stored in the cockpit, as there is minimum clearance between window hinge and trailer. (L. H. Wing)

SGS 2-33 - GENERAL MAINTENANCE

The sailplane can be serviced with a minimum of lubricants; a good grade of lubricating oil or powdered graphite and No. 2 cup grease.

1. Lubrication:

See Figure 1.

- a. Lubricating oil should be used at the following points, except that in dry and dusty conditions, powdered graphite is recommended on the exposed hinge points.

Aileron hinges	Elevator hinges
Rudder hinges	Dive-Brake hinges
* Torque Tube bearings	Dive-Brake Control bellcrank

- b. Lubricate all oil, (or graphite) points, every 20 hours flying time or 6 months elapsed time, whichever is sooner.

NOTES:

- 1. Rod end Bearings and Control Pulleys - are the sealed type and require no lubrication under normal conditions.
- *2. The Torque Tube bearings may be lubricated with cup grease whenever the aircraft undergoes major disassembly.

Flight Limitations for 2-33 and 2-33A

In any aircraft, it is important to know the operating limits and that exceeding these limits can highly endanger the aircraft and its occupants. The following information is provided for the 2-33 and 2-33A at 1,040 lbs. gross weight.

The speeds with which you should be familiar are:

Placard Speed (never exceed) with or without Dive Brakes open	98 mph
Placard Speed (never exceed) for aero tow	98 mph
Speed to begin maneuvering with caution	65 mph
Placard Speed (Never exceed) for auto or winch tow	69 mph

In the 2-33, at speeds over 65 mph, the pilot must maneuver with caution. The maximum load factor which should be attained in flight is 4.67 G, and the pilot can easily exceed this in abrupt maneuvers at speeds over 65 mph. The speeds between 65 mph and the 98 mph placard should be treated as a cautionary range and maneuvering within this range should be gradually reduced to a minimum as velocity increases.

The 2-33 limit load factor of 4.67 should not be exceeded in operation. A safety factor of 1.5 is required by the FAA which gives an ultimate load factor of 7.0, but this safety factor is required to allow for material variations and inadvertent atmospheric conditions. Because of its light wing loading, a sailplane can develop very high loads if speed limitations are not rigidly adhered to. Normal category light airplanes are usually certified to a limit load factor of 3.8 G's.

Understanding the Flight Envelope

The FAA required design flight envelope is presented on the following page. On the horizontal axis are indicated velocities in miles per hour, and on the vertical axis are load factors expressed in "G" units.

The straight lines labeled "gust load factors" represent the effect of the FAA required 24 ft. per second gust on the sailplane as speed varies. They diverge from the one "G" situation where the glider would be at rest or in perfectly balanced level flight. The curved lines diverging from zero "G" represent forces which can be induced by moving the elevator (or other) control abruptly at various speeds. As you can see, the faster you fly the more effect moving your controls will have. Gusts will also have more effect as speed increases.

The speed for maneuvering with caution occurs where "G" loading from an abruptly moved control meets the 4.67 limit load factor. Assuming smooth and limited movement of the controls, the placard or "red-line" speed occurs where gusts could meet the 4.67 limit load factor without any maneuvering.

Understanding the Flight Envelope cont'd.:

Normal placard speeds are reduced 10% from design speeds to provide an extra margin of safety. Thus, on the graph, the diagonal hatched area indicates speeds at which you must use caution in maneuvers. You should neither maneuver nor fly so fast as to expose your ship to loads within the cross-hatched area marked, "NO".

It can be inferred from the graph that abrupt maneuvering in gusty conditions is dangerous and can lead to very high "G" loads.

In normal operation the major cases of high "G" loads are tight spirals in thermals which would not normally exceed 2 or 2.5 G's. Winch or auto towing can produce high loads, but if the auto-winch placard speed is observed, this will be within safe limits. The best ground launch climb is obtained at speeds well below placard limits.

Although the 2-33 is capable of performing some aerobatic maneuvers, they must be done with extreme caution since it is very easy to greatly exceed the placard or cautionary speeds in improperly executed maneuvers. Inverted flight is not permitted. Aerobatics should not be done without previous instruction in two-place aircraft.

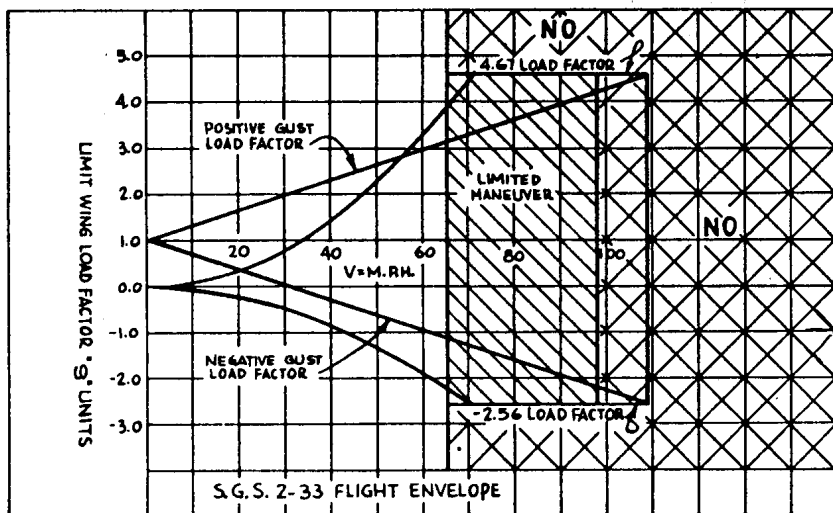

C. Installation of Stabilizer and Elevator (cont'd.)

3. Place stabilizer struts in position and secure each with 3/16" bolts, AN960-10 washer, AN310 nut and cotter pin.
4. Connect elevator push-rod to elevator horn with AN4-6 bolt, AN310-4 nut, AN960-416 washer and cotter pin. Use caution not to overtighten nut and cause binding of the elevator control.

D. INSTALLATION AND REMOVAL OF FIN AND RUDDER:

For normal handling and trailering, the Fin and Rudder Assembly are left attached to the fuselage. However, if an occasion arises where the Fin must be removed from the Fuselage, follow the procedure listed below.

1. Fin Removal from Fuselage:
 - a. Disconnect rudder cables from rudder horn.
 - b. Remove screws attaching metal fairing to fin. This includes the AN520-10 screw and nut.
 - c. Remove inspection hole covers from aft fuselage.
 - d. Remove the (5) AN3 bolts attaching fin to fuselage.
 - e. Remove fin by lifting up, tilting it slightly to the right to clear the notch in the fin spar past the elevator push tube.
2. To install the Fin and Rudder Assembly reverse the procedure outlined in a. through e. above.
 - *a. The fin rear spar is attached to the fuselage by (4) AN3-5A bolts, (4) AN960-10 washers and (4) AN365-1032 nuts.
 - b. The fin forward-fitting is attached to the fuselage by (1) AN3-14A bolt, (1) AN960-10 washer and (1) AN365-1032 nut.
 - c. The rudder cables are attached to the rudder horn by (2) AN3-6 bolts, (2) AN960-10 washers, (2) AN310-3 nuts and (2) AN380-2-2 cotter pins.
 - d. The fin fairing is installed with (10) #4 x 1/4, Type Z, "PK" screws, (1) AN520-10-54 screw, (1) AN960-10 washer and (1) AN365-1032 nut.
3. In case the rudder has been removed from the fin, the hinge hardware for re-assembly is as follows:
 - a. At upper and center hinges - AN3-11 bolt, AN960-10 washer, AN310-3 nut and AN380-2-2 cotter pin.
 - b. At lower hinge - AN4-11 bolt, AN960-416 washers (2 each side of male hinge inside female segment), AN310-4 nut (with washer) and AN380-2-2 cotter pin.

*On ship 508 and up, the rear fin spar is attached using (4) each AN4-5A bolt, AN365-428 nut, AN960-416 washer (under nut), AN960-416L (under bolt head). All previous Ser. No's. may have the fin spar modified and use this hardware per drawing 33924D, Rev. A.

B. Assembly of the Aircraft (cont'd.)

3. Raise L. H. strut and attach to wing strut-fitting with P/N 32428B-1 bolt (special, P/N 33428B-3 collar, AN310-5 castle nut. Safety with #2 commercial safety pin.
4. Attach aileron push-rod to bellcrank on fuselage. This connection is made with (1) AN393-25 Clevis Pin and (1) Commercial safety pin.
5. Repeat above items 1 thru 4 for R. H. Wing. While sliding this wing in position, check to make sure that the dive-brake torque tube fittings are properly positioned to mesh (bolt into opposite slot), with dive-brakes on both wings closed.
6. Attach the dive-brake push tube (in fuselage) to the bellcrank on the torque tube of the L. H. Wing. Use an AN393-21 pin and secure with a #1 commercial safety pin.
7. Check items 1 thru 6 on each wing for proper installation and safetying.
8. The wing tip wheel is installed by inserting the ferrule on the spring assembly into a hole in the lower side of the wing. Secure in place using an AN3-6A bolt, with a washer under the head, screwed into a 10-32 nut plate which is fastened to the internal bracket assembly.
9. Install wing gap cover, the Plexiglass Assembly is put in place between the wing leading edges and secured with the "airloc" studs. The aft gap-cover assembly is then hooked over the wing trailing edges, the pierced-strap inserted in the takeup mechanism and tightened with a screwdriver. The padding assembly is then put in place between the wing roots and secured to the root rib on each side.

C. INSTALLATION OF STABILIZER AND ELEVATOR:

1. It is seldom necessary to remove the elevator and stabilizer of this aircraft for normal purposes. However, if they have been removed, the following method should be used for re-assembly.
2. Place assembled elevator and stabilizer into position, with strut lugs on stabilizer on the bottom side. Secure with AN4 bolts, AN960-416L washers and AN365-428 nuts thru stabilizer front and rear spar fittings, and fuselage attach fittings.

2-33A GROSS WEIGHT
and
BALANCE CALCULATIONS

When preparing for any particular flight the pilot must answer two questions:

1. Is my weight and my passenger's weight within the maximum limits of gross weight for this flight? and
2. Is the sailplane properly balanced for this flight?

The following procedure is designed to help the pilot determine the actual weight and balance of his 2-33A for any particular flight loading. To do this, we calculate the moments of the aircraft and each occupant using the equation weight X arm = moment (WA = M).

The sailplane must be balanced within forward and rearward C.G. limits when it is flown. These limits are defined at Sta. 78.20" for the forward limit, and Sta. 86.10" for the rear limit. This figure is constant for all 2-33's. The weight and empty center of gravity of each specific 2-33 is determined at manufacture, or on any subsequent reweighing, so this information is available to any pilot from Schweizer Form I-4427 to calculate his operational weight and balance. Also known are the arm (or distance aft of Station "O") for the optional ballast, the front pilot and the rear pilot. With this given information we can develop a form for calculating the actual arm (or c.g. location) for the sailplane for any particular loading.

Items Known:

Front Pilot Weight _____ Sta. 43.80

Rear Pilot Weight _____ Sta. 74.70

Sailplane Empty Weight _____ 2-33 s/n _____

Removable Ballast Weight - 0 or 19½ lbs. (all 2-33's)

Baggage Capacity — None allowed.

Sailplane Empty C.G. _____ 2-33 s/n _____

Limits: Forward: Sta. 78.20 (all 2-33's)

Rear: Sta. 86.10 (all 2-33's)

To Be Determined:

1. Whether the actual CG of the particular 2-33 to be flown will fall within the above limits.
2. Whether total gross weight is not greater than the maximum allowable 1,040 lbs. for any 2-33.

WEIGHT AND BALANCE CALCULATIONS

SGS 2-33 or 2-33A

Example Sailplane Serial Number 369
(See Form I 4427 on next page)

My Sailplane - Serial Number _____
(Refer to Form I-4427 for your aircraft)

ITEM

	WEIGHT	ARM	MOMENT	WEIGHT	ARM	MOMENT
Sailplane empty weight & empty C. G.	612	96.12	58,825			
Front Pilot Weight	170	43.80	7,446		43.80	
Rear Pilot Weight	150	74.70	11,205		74.70	
Ballast, if used	0	14.75	- 0 -		14.75	
Total Moment			<u>77,476</u>			
Total Weight	<u>932</u>					
Total Moment		<u>83.13</u>	Actual flying	Total Moment		Actual flying
Total Weight	<u>932</u>		CG	Total Weight		CG

This CG is between the limits of Sta. 78.20 and 86.10, and gross weight is less than 1,040 lbs., so this sailplane has a proper flight weight and balance loading.

1. Is this between the CG limits?

2. Is total weight less than 1,040 lbs.?

SCHWEIZER AIRCRAFT CORP.
ELMIRA, NEW YORK 14902

Form F-114
3/78

SGS 2-33 - ERECTION PROCEDURE

A. TO REMOVE A/C FROM TRAILER:

1. Remove trailer from towing vehicle and block wheels.
2. Raise rear of trailer and block in position with sawhorse, jack or other suitable means.
3. Remove wing-to-trailer tie-down from wing tip skid brace from L. H. wing. (Note: R. H. wing is mounted on the L. H. side of trailer and L. H. wing on R. H. side of trailer.)
4. Remove upper wing-to-trailer attach pin, support the wing to prevent twisting.
5. Remove lower wing to trailer attach pin and remove wing from trailer and place on ground.
6. Repeat steps 3 thru 5 for R. H. wing.
7. Remove blocking means from rear of trailer. Raise and block the front end so that aft end of the trailer rests on the ground.
8. Remove the rear tail wheel bracket-to-trailer jack attachment, bolt and support fuselage.
9. Remove front fuselage tie downs and carefully roll the ship aft out of wheel well and off trailer into assembly position.

B. ASSEMBLY OF THE AIRCRAFT:

1. With the fuselage in an upright position, attach wing struts to fuselage with (2) AN7 (7/16") bolts and #2 Commercial safety pins.

NOTE: The wing and strut attach bolts must have a grip-length of 1-13/16" min., to avoid threads in bearing.
2. Lift and place L. H. wing in position and attach to fuselage with an AN7 (7/16") bolt in front fitting and an AN6 (3/8") bolt in rear fitting. Install #2 Commercial safety pins in bolts.

ELMIRA, NEW YORK 14902

WEIGHT & BALANCE, MODEL NO. SGS 2-33A SER. NO. 369 REG. NO. N-33969 DATE February 27, 1975

ERECTION AND MAINTENANCE INSTRUCTIONS
MODEL SGS 2-33

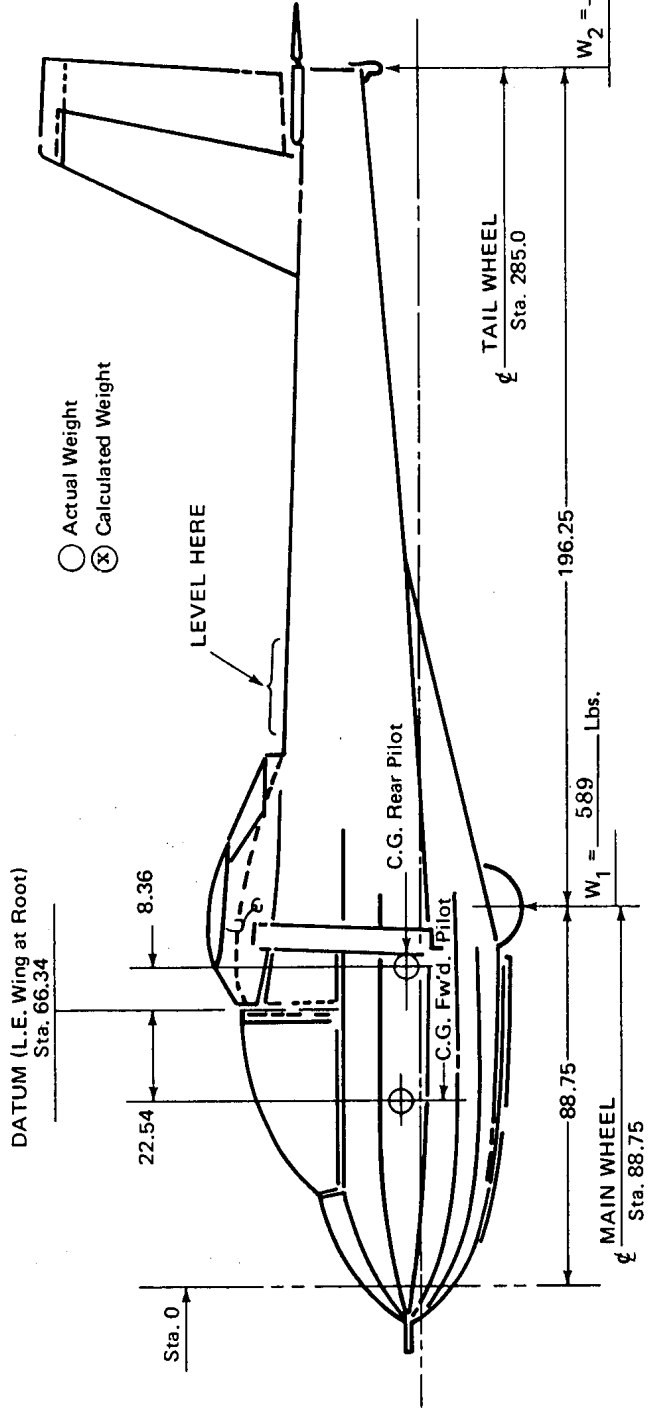

Empty Wt. = $W_1 + W_2 = 589 + 23 = 612$ Lbs.

Empty C.G. (Sta.) = $W_2 \times 196.25 + 88.75 = 23 \times 196.25 + 88.75 = \text{Sta. } 96.12$
 $\frac{W_1 + W_2}{612}$

SHIP AS WEIGHED INCLUDES EQUIPMENT LISTED ON I-4427-3

NOTES: See Glider Data Sheet No. G2EA - Fw'd Pilot C.G. at Sta. 43.80 - Rear Pilot C.G. at Sta. 74.70
 CLASS II, UTILITY: C.G. Limits - Sta. 78.20 to Sta. 86.10, or, 11.86" to 19.76" Aft Datum.

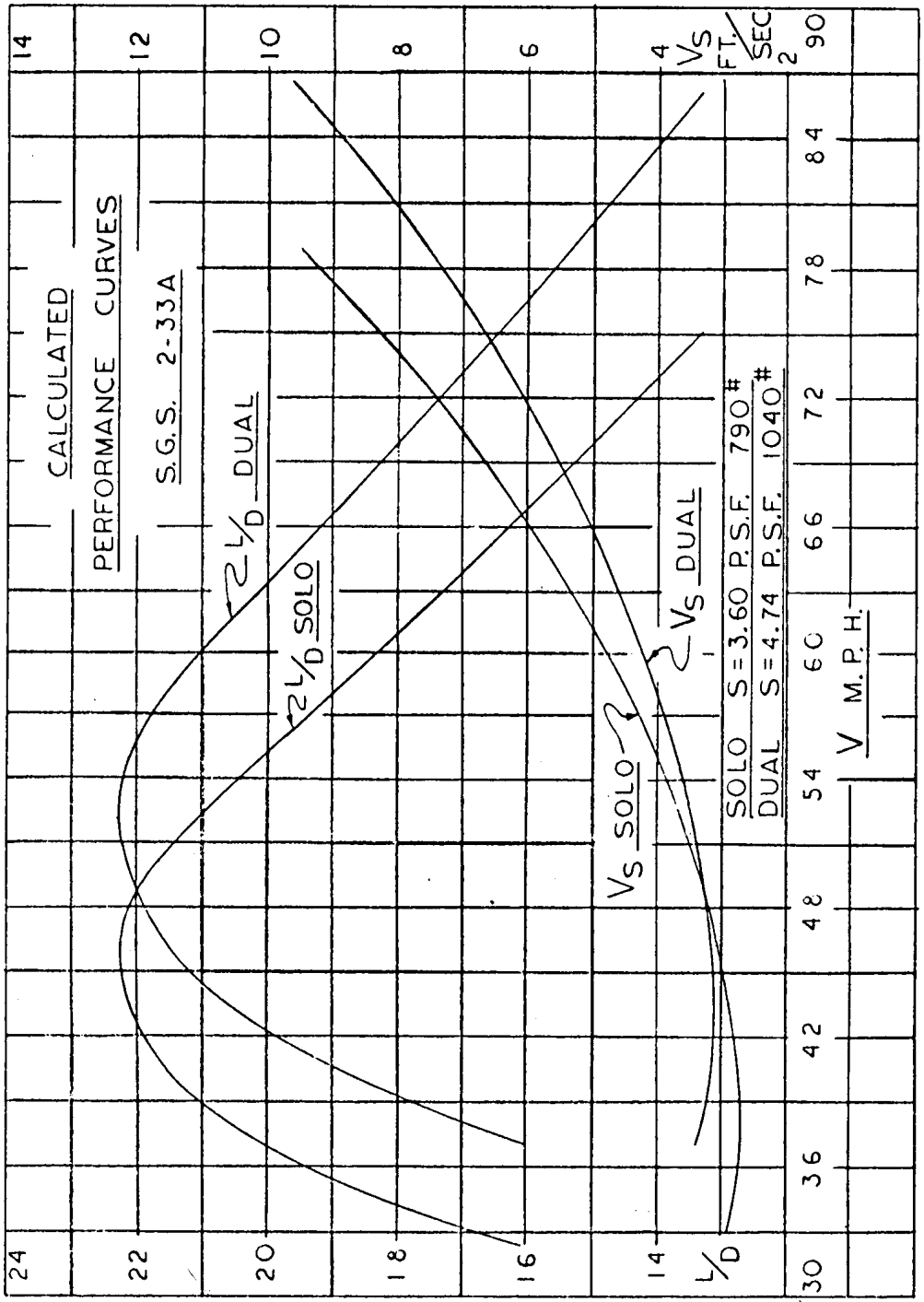
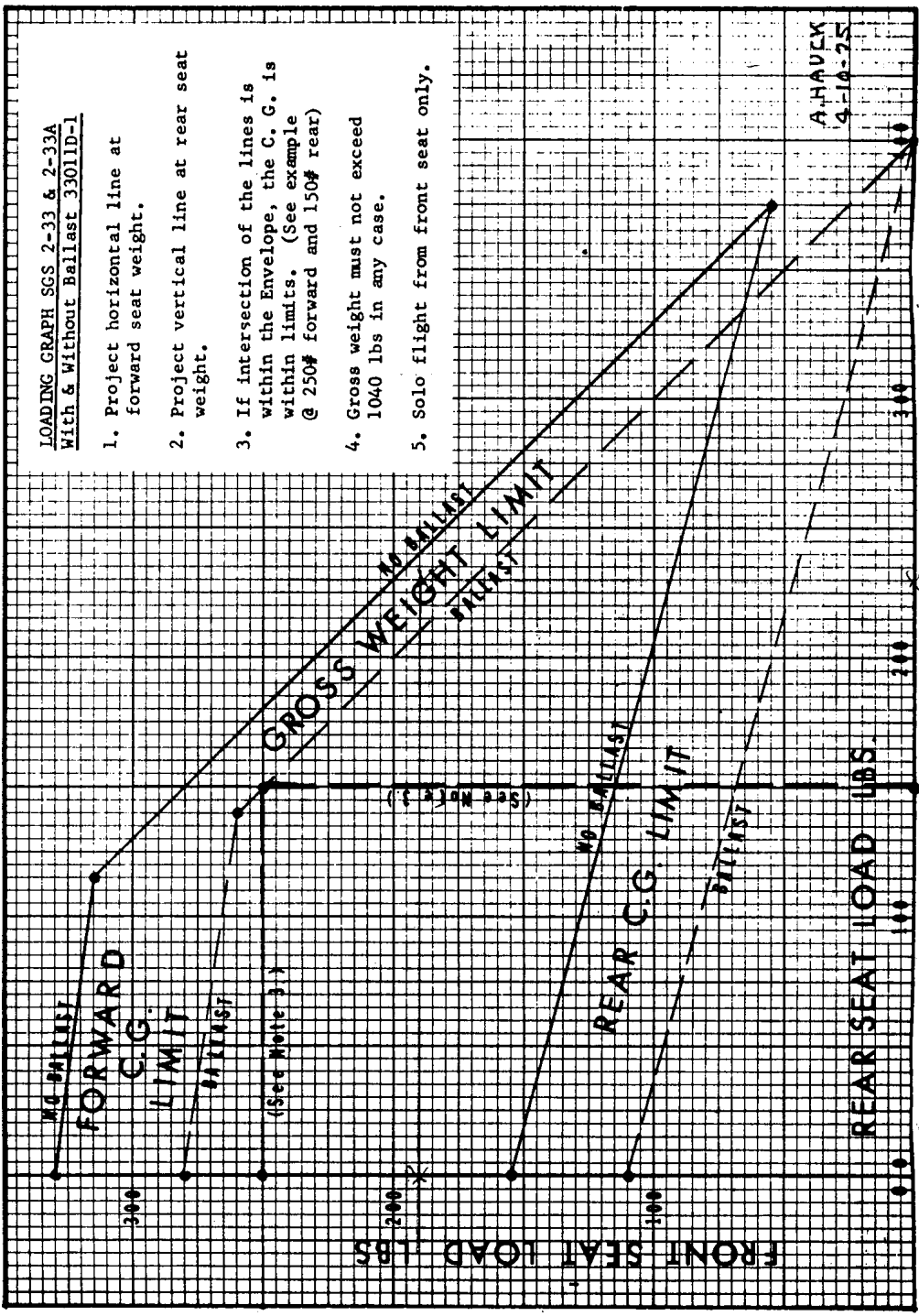

**DEPARTMENT OF TRANSPORTATION
FEDERAL AVIATION ADMINISTRATION**

G2EA
SCHWEIZER
Revision 2
SGS 2-33
SGS 2-33A
SGS 2-33AK
August 1, 1973

GLIDER DATA SHEET NO. G2EA

This data sheet which is a part of type certificate No. G2EA prescribes conditions and limitations under which the product for which the type certificate was issued meets the airworthiness requirements of the Federal Aviation Regulations.

Type Certificate Holder Schweizer Aircraft Corporation
County Airport
Elmira, New York 14902

I - Model SGS 2-33, 2 PCLM, Approved February 10, 1967; Model SGS 2-33A, 2 PCLM, Approved March 7, 1968; Model SGS 2-33AK, 2 PCLM, Approved April 19, 1973. Model SGS 2-33A same as SGS 2-33 except for larger rudder with aerodynamic balance; Model SGS 2-33AK is same as Model SGS 2-33A constructed from a kit (see Note 4 for eligibility requirements)

Type	Class II, Utility		
Airspeed limits (CAS)	Vne-Glide or dive		98 m.p.h.
	Vta-Airplane tow		98 m.p.h.
	Vtaw-Auto-winch tow		69 m.p.h.
	C.G. range		
	(±11.9) to (±19.8) (Fuselage Sta. 78.2 to 86.1)		
Maximum weight	1040 lb.		
No. seats	2 (1 at -23) (1 at +8)		
Baggage	None		
Control surface movements	Elevator		Limits
	Up	23°	Down 23° ± 2°
	Rudder	Left 30°	Right 30° ± 2°
	Aileron	Up 38°	Down 18° ± 2°
	Dive Brakes	Top Up 85°	Bot. Down 75° ± 5°
Serial nos. eligible	1 and up		

Specifications Pertinent to All Models

Datum	Wing leading edge at root (Fuselage Sta. 66.3)
M.A.C.	53.54 in. (L.E. of M.A.C. 2.35 in. aft of wing leading edge at root)
Leveling means	Top of upper longeron aft of wing.
Certification basis	FAR 21 and Basic Glider Criteria Handbook, 1962. Date of Application for Type Certificate April 1, 1966. Type Certificate No. G2EA issued February 10, 1967.

Page No.	1	2
Rev. No.	2	2

Production basis	Production Certificate No. 101
Equipment:	The basic equipment as prescribed in the applicable airworthiness regulations (See certification basis) must be installed in the aircraft for certification.

- NOTE 1. Suitable placards to cover the various pilot and passenger weights must be installed in full view of the pilot as determined from the manufacturer's weight and balance report.
- NOTE 2. The following placards must be installed in full view of the pilot:
- (a) "Solo front seat only."
 - (b) "Max. glide or dive 98 m.p.h.
 Max. aero tow 98 m.p.h.
 Max. auto-winch tow 69 m.p.h."
- NOTE 3. Approved safety belt and shoulder harness required for each occupant.
- NOTE 4. Each Model SGS 2-33A glider assembled from a kit is designated Model SGS-2-33AK. These K models will be eligible for an airworthiness certificate when accompanied by an affidavit certifying that the glider is constructed in exact accordance with the approved drawings and manual, and that the parts and materials furnished by the manufacturer in the kit have been used; and further when the following inspections have been satisfactorily passed:
- (a) An inspection for workmanship, materials, and conformity before any covering is applied. (All woodwork may be sealed.)
 - (b) A final inspection of the completed glider.
 - (c) Check of flight characteristics.

...END...